

International + Linears

Summary:

- World-wide ac input ranges and safety standards
- Industry standard packages
- Commercial UL/CSA TUV/IEC approved—models to UL/CSA 60950; EN/IEC60950-1
- Burn-in with cycling; 3-year warranty
- Capacitors have highest CV & ripple current ratings
- Medical Approved to UL2601-1/60601-1, IEC60601-1 and CSA601.1
- Medical leakage 10 μ A
- MTBF 200,000+ hours per MIL-HDBK-217D (most units)
- All electrolytic caps rated at 105°C
- Transformer insulation meets Class F (155°C)
- Exceed FCC and CISPR22, Class B conducted emissions
- RoHS Compliant models available (G suffix)
- $\text{C}\epsilon$ marked to LVD



SPECIFICATIONS

Ac Input 100, 120 and 240 Vac: +10%, -13%; 215 Vac: +12%, -11%; 47 to 63Hz. Tolerance for 230 Vac operation is +15%, -10%. Derate output current 10% for 50 Hz operation.	Remote Sensing Provided on all models; open sense lead protection built-in (except HA & HTAA series).
Dc Output See voltage rating chart. Adjustment range $\pm 5\%$ minimum except HA series.	Stability $\pm 0.05\%$ for 24 hours after warmup.
Line Regulation $\pm 0.05\%$ for a 10% change.	Temperature Rating 0 to 50°C full rated, derated linearly to 40% at 70°C.
Load Regulation $\pm 0.05\%$ for a 50% load change.	Temperature Coefficient $\pm 0.01\%/^{\circ}\text{C}$ maximum.
Output Ripple 3 mV +0.05% of output voltage, peak to peak maximum. All "3-terminal regulator" outputs: 3 mV +0.2% peak to peak maximum.	Efficiency 5 V units: 45%; 12 and 15 V units: 55%; 20 and 24 V units: 60%.
Transient Response <50 microseconds for 50% load change.	Logic Inhibit and Current-Share F & G models.
Short Circuit Protection Automatic current limit/foldback.	Medical Stock and Vibration Per Mil-Std-810D, Method 514.3, Category 1, Procedure 1. Per Mil-Std-810D, Method 516.3, Procedure III.
Oversvoltage Protection Built-in on all 5 V models, set at 6.2 V ± 0.4 V. Other models use optional over-voltage protection.	Storage -40 to +85 °C.

Commercial Model (Single)	Medical Model	Voltage	Current	Case
HB2-3-A+G		2V	3 A	B
HC2-6-A+G		2V	6 A	C
HE2-18-A+G		2V	18 A	E
	ML5-1-OV-A	5V	1.0 A	L
HA5-1.5-OV-A+G		5V	1.5 A	B
HB5-3-OV-A+G		5V	3 A	B
HC5-6-OV-A+G		5V	6 A	C
HN5-9-OV-A+G		5V	9 A	N
HD5-12-OV-A+G		5V	12 A	D
HE5-18-OV-A+G		5V	18 A	E
F5-25-OV-A+*G		5V	25 A	F
G5-35-OV-A+ *(1)		5V	35 A	G
CP197-A+G		5V	50 A	G
	ML12-0.5-A	12V	0.5 A	L
HA15-0.9-A+ (12 VG)		12V	0.9 A	B
HB12-1-7-A+G	MB12-1-7-A	12V	1.7 A	B
HC12-3.4-A+G	MC12-3.4-A	12V	3.4 A	C
HN12-5.1-A+G		12V	5.1 A	N
HD12-6.8-A+G	MD12-6.8-A	12V	6.8 A	D
HE12-10-2-A+G		12V	10.2 A	E
	ML15-0.4-A	15V	.4 A	L
HA15-0.9-A+G		15V	0.9 A	B
HB15-1.5-A+G	MB15-1.5-A	15V	1.5 A	B
HC15-3-A+G	MC15-3-A	15V	3 A	C
HN15-4.5-A+G		15V	4.5 A	N
HD15-6-A+G	MD15-6-A	15V	6 A	D
HE15-9-A+G *		15V	9 A	E
F15-15-A+G *		15V	15 A	F
HA24-0.5-A+G		24V	0.5 A	B
HB24-1.2-A+G	MB24-1.2-A	24V	1.2 A	B
HC24-2.4-A+G	MC24-2.4-A	24V	2.4 A	C
HN24-3.6-A+G		24V	3.6 A	N
HD24-4.8-A+G	MD24-4.8-A	24V	4.8 A	D
HE24-7.2-A+G *		24V	7.2 A	E
F24-12-A+G *		24V	12 A	F
HA24-0.5-A+ (24 V)G		28V	0.5 A	B
HB28-1-A+G	MB28-1-A	28V	1 A	B
HC28-2-A+G	MC28-2-A	28V	2 A	C
HN28-3-A+G		28V	3 A	N
HD28-4-A+G	MD28-4-A	28V	4 A	D
HE28-6-A+G *		28V	6 A	E
F24-12-A+* (28 V)G		28V	10 A	F
HB48-0.5-A+G		48V	0.5 A	B
HC48-1-A+G		48V	1 A	C
HD48-3-A+G **		48V	3 A	D
HE48-4-A+G		48V	4 A	E
F48-6-A+G *		48V	6 A	F

Notes:

1. All single output models have isolated outputs.
2. Model G5-50-OV-A+ not RoHS compliant

Commercial Model (Dual)	Medical Model	Output 1	Output 2	Case
HAA5-1.5-OV-A+G		5 V @ 1.5 A	5 V @ 1.5 A	AA
HBB5-3-OV-A+G		5 V @ 3 A	5 V @ 3 A	BB
HCC5-6-OV-A+G		5 V @ 6 A	5 V @ 6 A	CC
HAA512-A+G	MAA512-A	5 V @ 2 A	9 to 15 V (adj) @ 0.5 A	AA
HBB512-A+G	MBB512-A	5 V @ 3 A	9 to 15 V (adj) @ 1.2 A	BB
HCC512-A+G **	MCC512-A	5 V @ 6 A	9 to 15 V (adj) @ 2.5 A	CC
HAA524-A+G **	MAA524-A	5 V @ 2 A	18 to 24 V (adj) @ 0.3 A	AA
HBB524-A+G	MBB524-A	5 V @ 3 A	18 to 24 V (adj) @ 0.8 A	BB
HCC524-A+G	MCC524-A	5 V @ 6 A	18 to 24 V (adj) @ 2 A	CC
HAD12-0.4-A+G		+12 V @ 0.4 A	-12 V @ 0.4 A	B
	MLL12-0.25-A	+12 V @ 0.25 A	-12 V @ 0.25 A	L
	MLL15-0.2-A	+15 V @ 0.2 A	-15 V @ 0.2 A	L
HAD15-0.4-A+G		+15 V @ 0.4 A	-15 V @ 0.4 A	B
HAA15-0.8-A+G	MAA15-0.8-A	+15 V @ 0.8 A	-15 V @ 0.8 A ***	AA
HBB15-1.5-A+G	MBB15-1.5-A	+15 V @ 1.5 A	-15 V @ 1.5 A ***	BB
HCC15-3-A+G	MCC15-3-A	+15 V @ 3 A	-15 V @ 3 A ***	CC
HDD15-5-A+G		+15 V @ 5 A	-15 V @ 5 A ***	E
HAA24-0.6-A+G		+18 to 24 V @ 0.4/0.6 A	-18 to 24 V @ 0.4/0.6 A	AA
CP323-A+G		+5 V @ 2 A	+12 V @ 4 A	BB

** May require fan cooling

*** No. 2 output usable at -5 V, rate at 1/2 of 15 V current rating.

Commercial Model (Triple)	Medical Model	Output 1	Output 2	Output 3	Case
	MTLL-5W-A	5 V @ 0.5 A	+12 to 15 V @ 0.1 A	-12 to 15 V @ 0.1 A ***	L
HTAA-16W-A+G	MTAA-16W-A	5 V @ 2 A	+12 to 15 V @ 0.4/0.4 A	-12 to 15 V @ 0.4/0.4 A ***	AA
HBAA40W-A+G	MBAA40W-A	5 V @ 3 A	+12 to 15 V @ 1/0.8 A	-12 to 15 V @ 1/0.8 A ***	BAA
HCBB105W-A+G **		5 V @ 3 A	+12 to 15 V @ 3.4/3.0 A	-12 to 15 V @ 3.4/3.0 A ***	CBB
HCAA60W-A+G	MCAA60W-A	5 V @ 6 A	+12 to 15 V @ 1/0.8 A	-12 to 15 V @ 1/0.8 A ***	D
HCBB75W-A+G	MCBB75W-A	5 V @ 6 A	+12 to 15 V @ 1.7/1.5 A	-12 to 15 V @ 1.7/1.5 A ***	CBB
CP131-A+G		5 V @ 8 A	+12 to 15 V @ 1.7/1.5 A	-12 to 15 V @ 1.7/1.5 A ***	NBB
HDBB105W-A+G *		5 V @ 12 A	+12 to 15 V @ 1.7/1.5 A	-12 to 15 V @ 1.7/1.5 A ***	DBB
HDCC150W-A+G *		5 V @ 12 A	+12 to 15 V @ 3.4/3 A	-12 to 15 V @ 3.4/3 A ***	DCC

*Requires fan cooling

** May require fan cooling

***No. 3 output usable at -5 V, rate at 1/2 of 15 V current rating.

Outputs rated at 9 to 15V, 12 to 15V, or 18 to 24V are user adjustable outputs.

All outputs without + or - sign are isolated outputs and may be referenced as either a positive or negative output.

FIXED DISK SERIES

Both models without UL, CSA or TUV

Commercial Model (Dual)	Output 1	Output 2	Output 3	Case
CP379-A+G	+5 V @ 6 A	+ 24 V @ 3.5/6 A PK	-5 or -12 @ 1.2 A	NBB
CP498-A+G	+5 V @ 6 A	+ 12 V @ 5/10 A PK	-12 V @ 0.5 A	NBB

CBB CASE (WT. 8 LB.)

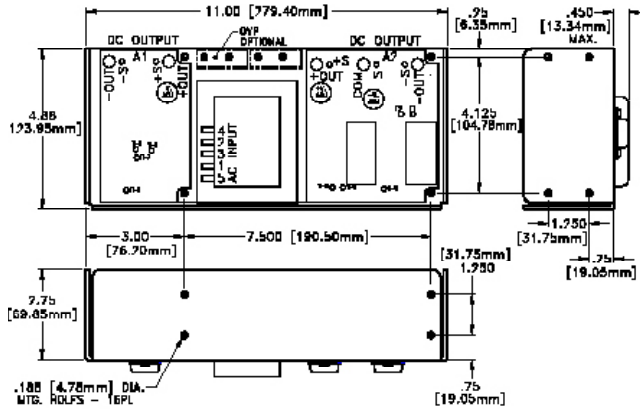

DBB CASE (WT. 11 LB.)

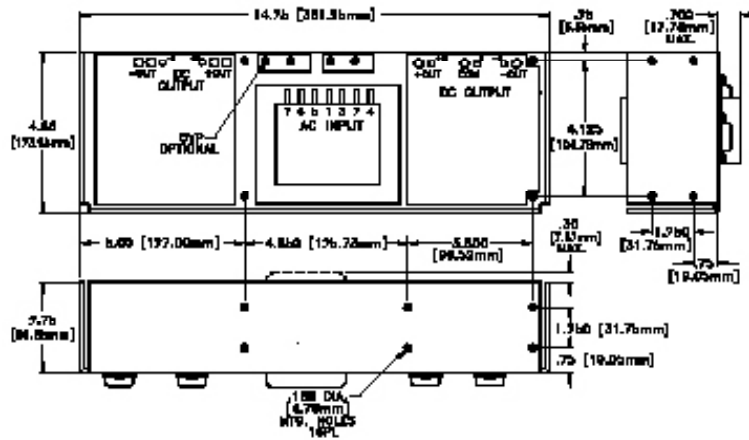

DCC CASE (WT. 12 LB.)

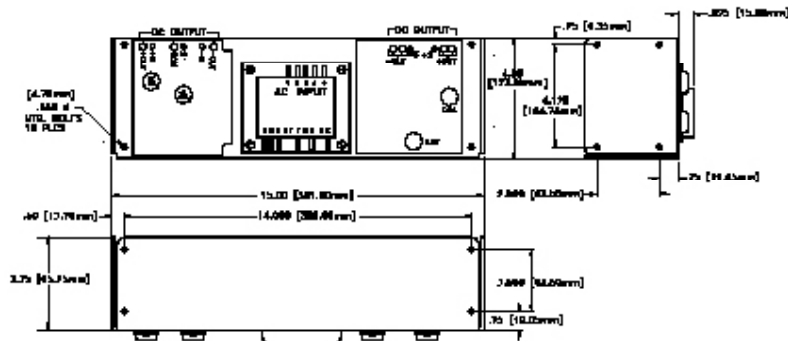

NBB CASE (WT. 12 LB.)

